

## 600Vac, 5x20mm, Fast Acting, Ceramic Tube Fuses

### HV510 Series

#### Description

- Fast Acting, high breaking capacity
- 5x20mm physical size
- Ceramic tube, Silver plated copper cap construction
- Designed to UL248-1
- Lead Free and Halogen free material



Electrical Characteristics			
Rated Current	1.0In	2.0In	4.0In
200mA – 600mA	4 hour min.	—	120 sec max.
1A–20A	4 hour min.	120 sec max.	—

#### Specifications

Part No.	Rated Voltage	Rated Current	Breaking Capacity (A)	Typical Cold Resistance (mOhms)	Typical Voltage Drop (mV)	Typical Pre-Arcing I <sup>2</sup> t (A <sup>2</sup> Sec)
	AC		AC			
HV510.0.2	600V	200mA	1000A	1750	333	0.032
HV510.0.25		250mA		878	217	0.053
HV510.0.4		400mA		663	278	0.172
HV510.0.5		500mA		382	190	0.287
HV510.0.6		600mA		360	234	0.396
HV510.1		1A		230	280	0.28
HV510.1.6		1.6A	200A	148	310	2.56
HV510.2		2A		100	248	1.68
HV510.2.5		2.5A		90	360	1.48
HV510.3.15		3.15A		49	215	4.86
HV510.4		4A		38	220	8
HV510.5		5A		29	200	16
HV510.6		6A		24	150	30
HV510.6.3		6.3A		19	162	48
HV510.8		8A		14	149	64
HV510.10		10A		12	166	90
HV510.12		12A		9.5	160	130
HV510.15		15A		7.3	165	225
HV510.16		16A		6.8	164	256
HV510.20		20A		5	150	520

\* DC Cold Resistance are measured at <10% of rated current in ambient temperature of 25°C

\* Typical Pre-arcing I<sup>2</sup>t are measured at 10In Current

## 600Vac, 5x20mm, Fast Acting, Ceramic Tube Fuses

### HV510 Series

#### Dimension

HV510.xxx

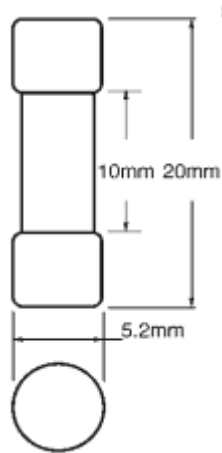

HV510.xxxP

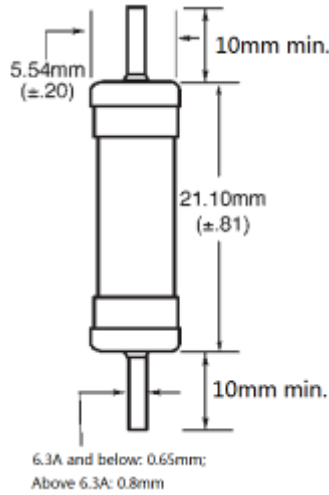

#### Temperature Derating Curve

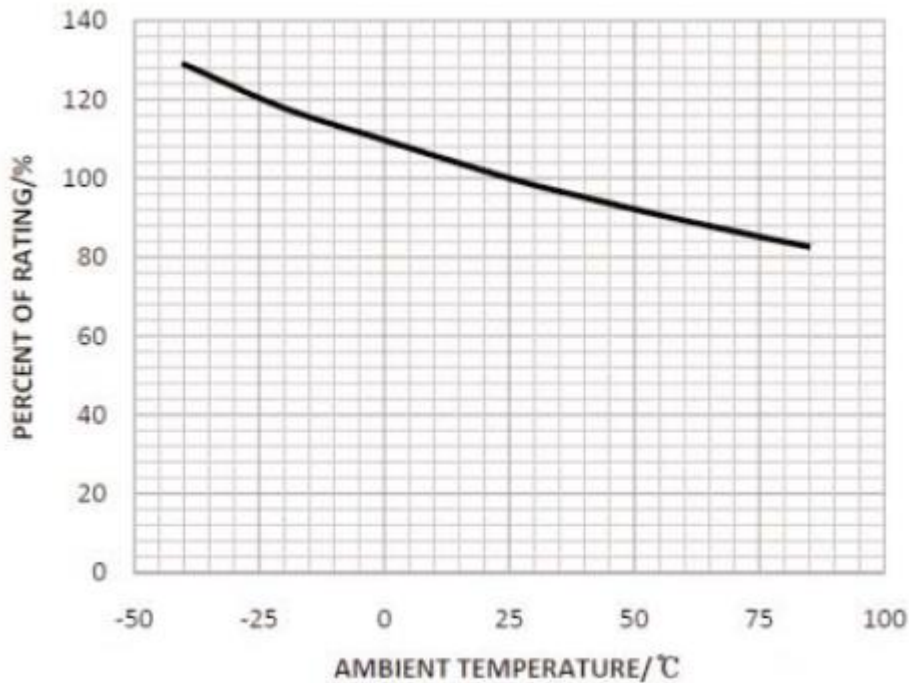

#### Package

cylindrical :(1A-3A) 40 pcs in one carton; other ratings is 500 pcs in one bag.

Leaded :100 pcs in one carton.

600Vac, 5x20mm, Fast Acting, Ceramic Tube Fuses

HV510 Series

Time-Current Characteristics

